

技术规范 Technical specification

设计依据 Design Basis	GB标准 Standard	ANSI标准 Standard
设计标准 Design standard	GB/12237	ANSI B16.34
连接法兰尺寸 Connecting Flange Size	GB/9113、JB/T79	ANSI B16.5
试验和检验 Test & inspection	JB/T9002	API 598

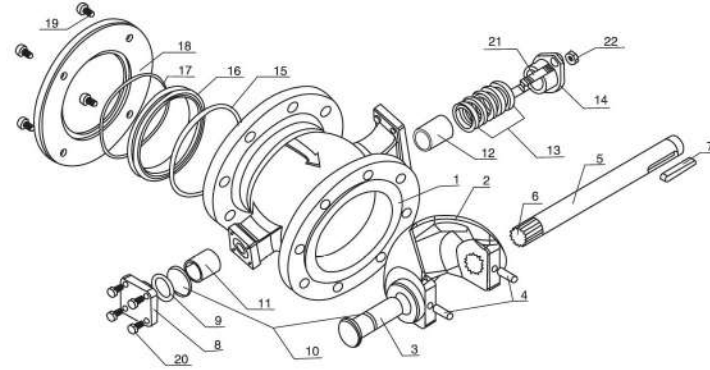

零件清单 Parts List

序号No.	名称	Name	数量(件) Quantity (pieces)	材料 Material
1	阀体	Body	1	WCB、CF8、CF8M、CF3、CF3M
2	阀芯	Spool	1	CF8、CF8M+镀硬铬或超音速喷涂
3	后阀杆	After steam	1	17-4PH、SS316
4	圆柱销	Cylindrical pin	2	SS304、SS316
5	前阀杆	Before steam	1	17-4PH、SS316
6	花键	Spline	1	17-4PH、SS316
7	平键	Flat key	1	Ss304、45#
8	后压盖	After gland	1	CF8、CF8M
9	O形圈	"O"-Ring	1	氟橡胶 Viton
10	调整垫	Adjust pad	各1	PTFE
11	自润滑轴承	Self-lubricating bearings	1	复合材料 Composite material
12	自润滑轴承	Self-lubricating bearings	1	复合材料 Composite material
13	填料	Packing	1组	PTFE
14	填料压盖	Gland	1	CF8
15	O形圈	"O"-Ring	1	氟橡胶 Viton
16	密封座	Seal block	1	PTFE、SS304、SS316+镀硬铬或超音速喷涂
17	密封座弹簧	Seal block spring	1	SS316
18	密封座盖	Sealing lid	1	Q235、SS304、SS316
19	内六角螺钉	inner Hexagon screw		SS304
20	六角螺钉	Hexagon screw	4	SS304
21	双头螺钉	Double-headed screw	2	SS304
22	六角螺母	Hexagon nut	2	Ss304

金属密封阀座  
Metal sealing seat

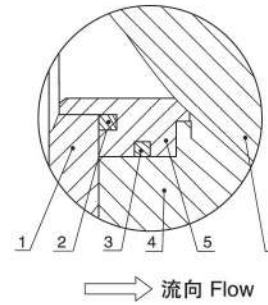

高温型金属密封阀座  
High-temperature metal seal seat

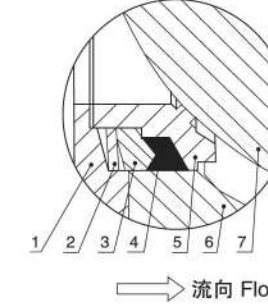

软阀座  
Soft Seat

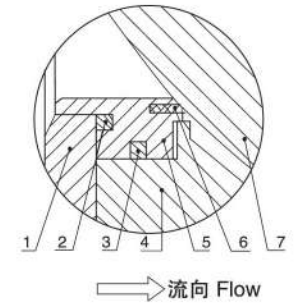

金属密封阀座 Metal sealing seat		
序号 No.	名称 Name	温度范围℃ Temperature range
1	密封阀盖 Seal Bonnet	-20~160℃ -20~230℃
2	弹簧 Spring	
3	O形圈 "O"-Ring	
4	阀体 Body	
5	密封座 Seal Block	
6	阀芯 Spool	

高温型金属密封阀座 High-temperature metal seal seat		
序号 No.	名称 Name	温度范围℃ Temperature range
1	密封阀盖 Seal Bonnet	-20~425℃
2	蝶簧 Butterfly Spring	
3	压圈 Flower ring	
4	石墨环 Graphite ring	
5	阀座 Seat	
6	阀体 Body	
7	阀芯 Spool	

软阀座 Soft Seat		
序号 No.	名称 Name	温度范围℃ Temperature range
1	密封阀盖 Seal Bonnet	-20~160℃
2	弹簧 Spring	
3	O形圈 "O"-Ring	
4	阀体 Body	
5	密封座 Seal Block	
6	密封圈(PTFE) Seal Ring	
7	阀芯 Spool	

气动法兰式V型球阀 OVQ640F(P、H、Y)-PN16、25、Class150  
Pneumatic Flange Type V-Type Ball Valve

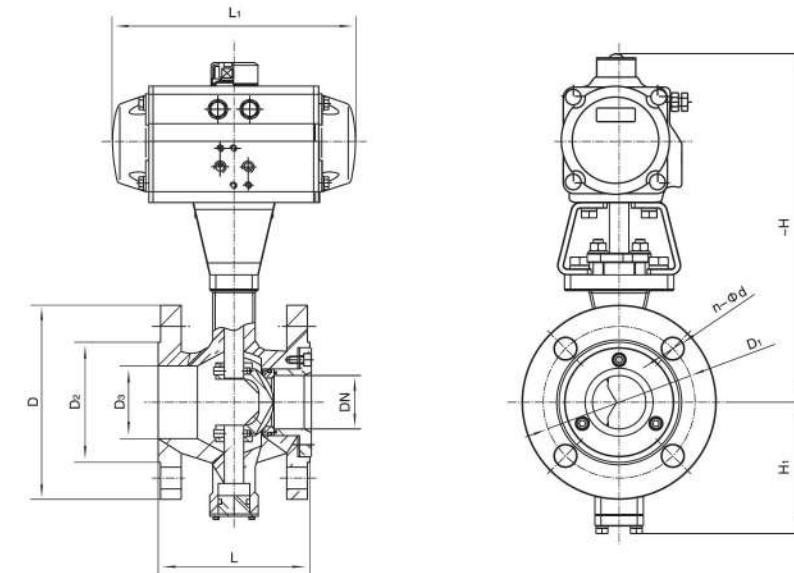

主要外形及连接法兰尺寸OVVQ640F(P、H、Y)-PN16(1.6MPa) Main Outline and Connecting Flange Size

公称通径 Nominal diameter DN	外形/连接尺寸 Outline/Connecting Size											执行器型号 Actuator Model
	L	L <sub>1</sub>	~H	H <sub>1</sub>	D	D <sub>1</sub>	D <sub>2</sub>	D <sub>3</sub>	C	f	n-Φd	
25	102	159/248	260/290	87	115	85	65	38	16	2	4-Φ14	AT063D/AT088S
32	105	159/248	267/297	87	140	100	76	42	18	3	4-Φ18	AT063D/AT088S
40	114	211/269	292/312	87	150	110	84	50	18	3	4-Φ18	AT075D/AT100S
50	124	248/269	292/312	97	165	125	99	60	20	3	4-Φ18	AT088D/AT100S
65	145	269/315	327/340	112	185	145	118	75	20	3	4-Φ18	AT100D/AT115S
80	165	315/345	359/381	112	200	160	132	94	20	3	8-Φ18	AT115D/AT125S
100	194	345/409	395/412	122	220	180	156	110	22	3	8-Φ18	AT125D/AT145S
125	213	409/438	399/416	142	250	210	184	135	22	3	8-Φ18	AT145D/AT160S
150	229	438/550	461/486	165	285	240	211	165	24	3	8-Φ22	AT160D/AT190S
200	243	550/600	509/553	195	340	295	266	210	24	3	12-Φ22	AT190D/AT210S
250	297	633/730	603/628	237	405	355	319	260	26	3	12-Φ26	AT240D/AT270S
300	334	730	790/825	287	460	410	370	310	28	4	12-Φ26	AT270D
350	414	1180	828/858	338	520	470	429	360	30	4	16-Φ26	AW20
400	490	1180	1063/-	390	580	525	480	410	32	4	16-Φ30	AW20
500	600	1320	-	510	715	650	609	510	36	4	16-Φ33	AW25

主要外形及连接法兰尺寸OVVQ640F(P、H、Y)-PN25(2.5MPa) Main Outline and Connecting Flange Size

公称通径 Nominal diameter DN	外形/连接尺寸 Outline/Connecting Size											执行器型号 Actuator Model
	L	L <sub>1</sub>	~H	H <sub>1</sub>	D	D <sub>1</sub>	D <sub>2</sub>	D <sub>3</sub>	C	f	n-Φd	
25	102	159/248	260/290	87	115	85	65	38	16	3	4-Φ14	AT063D/AT088S
32	105	159/248	267/297	87	140	100	76	42	18	3	4-Φ18	AT063D/AT088S
40	114	211/269	292/312	87	150	110	84	50	18	3	4-Φ18	AT075D/AT100S
50	124	248/315	312/325	97	165	125	99	60	20	3	4-Φ18	AT088D/AT115S
65	145	315/345	340/362	112	185	145	118	75	22	3	8-Φ18	AT115D/AT125S
80	165	345/409	381/398	112	200	160	132	94	24	3	8-Φ18	AT125D/AT145S
100	194	345/409	395/412	122	235	190	156	110	24	3	8-Φ22	AT125D/AT145S
125	213	409/438	416/441	142	270	220	184	135	26	3	8-Φ26	AT145D/AT160S
150	229	438/550	486/530	165	300	250	211	165	28	3	8-Φ26	AT160D/AT190S
200	243	550/600	553/578	195	360	310	274	210	30	3	12-Φ26	AT190D/AT210S
250	297	633/730	628/673	237	425	370	330	260	32	3	12-Φ30	AT240D/AT270S
300	334	730	725/755	281	485	430	389	310	34	4	16-Φ30	AT270D
350	414	1180	858/-	338	555	490	448	360	38	4	16-Φ33	AW20
400	490	1180	-/-	390	620	550	503	410	40	4	16-Φ36	AW20
500	600	1320	-/-	510	730	660	609	510	44	4	20-Φ36	AW25

※注：系列球阀结构长度及连接法兰尺寸可根据JB/T79标准或用户要求设计制造。  
 ※注：数据XXX/XXX分别是气动执行器双作用式/单作用式(弹簧复位)。  
 ※注：根据不同阀门扭矩、使用介质适配的执行器型号可能有所不同，相关尺寸随之变化。  
 ※注：以上执行器配置及数据均采用软密封(F、N、P)阀门，硬密封阀门的配置及数据请咨询本公司。  
 Note: The structural length and connecting flange size of ball valve series can be designed and manufactured as per JB/T79 standard or users' requirements  
 Note: Data XXX/XXX represent respectively the double-acting/single-acting type(spring reposition)of pneumatic actuator  
 Note: The relative sizes are subject to change responding to the difference in valve torque, medium and actuator model  
 Note: the above actuator configuration and data all use soft-sealed valves (F, N, P) and hard-sealed valves, or consulting us if you have more questions.

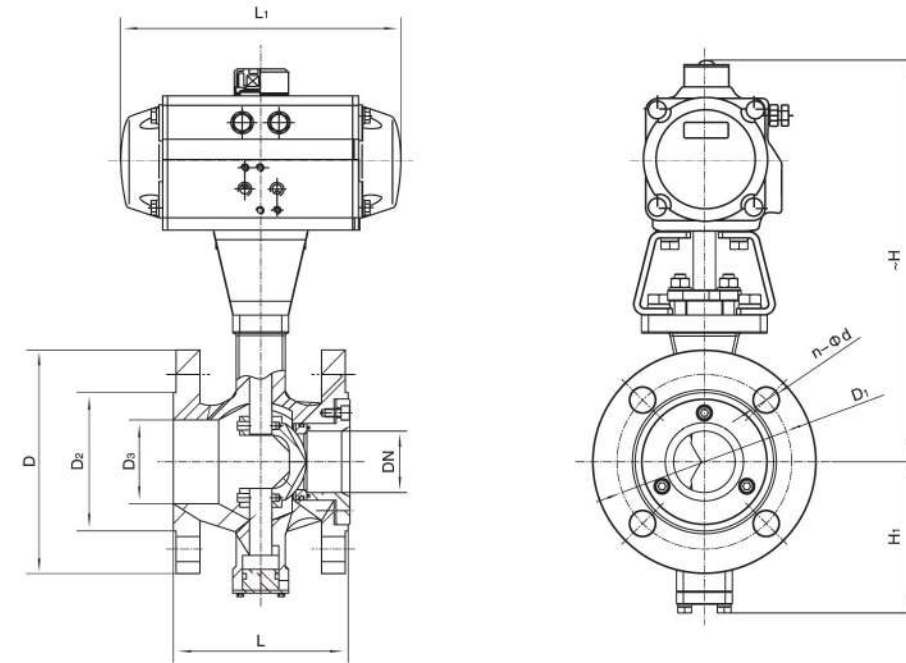

主要外形及连接法兰尺寸 Class150 Main Outline and Connecting Flange Size

公称通径 Nominal diameter DN	外形/连接尺寸 Outline/Connecting Size											执行器型号 Actuator Model
	L	L <sub>1</sub>	~H	H <sub>1</sub>	D	D <sub>1</sub>	D <sub>2</sub>	D <sub>3</sub>	C	f	n-Φd	
25	102	159/248	260/290	87	108	79.5	51	38	12	1.6	4-Φ16	AT063D/AT088S
32	105	159/248	267/297	87	117	88.9	64	42	13	1.6	4-Φ16	AT063D/AT088S
40	114	211/269	292/312	87	127	98.4	73	50	14.5	1.6	4-Φ16	AT075D/AT100S
50	124	248/269	292/312	97	152	120.6	92	60	15.8	1.6	4-Φ19	AT088D/AT100S
65	145	248/315	327/340	112	178	139.7	105	75	17.6	1.6	4-Φ19	AT088D/AT115S
80	165	315/345	359/381	112	190	152.4	127	94	19.1	1.6	4-Φ19	AT115D/AT125S
100	194	345/409	395/412	122	229	190.5	157	110	23.9	1.6	8-Φ19	AT125D/AT145S
125	213	409/438	399/416	142	254	216	186	135	23.9	1.6	8-Φ22	AT145D/AT160S
150	229	438/550	461/486	165	279	241.3	216	165	25.4	1.6	8-Φ22	AT160D/AT190S
200	243	550/600	509/553	195	343	298.5	270	210	28.6	1.6	8-Φ22	AT190D/AT210S
250	297	633/730	603/628	237	406	362	324	260	30.2	1.6	12-Φ25	AT240D/AT270S
300	334	730	790/825	281	483	432	381	310	31.8	1.6	12-Φ25	AT270D
350	414	1180	828/858	338	533	476	413	360	35	1.6	12-Φ29	AW20
400	490	1180	1063/-	390	597	539.5	470	410	36.6	1.6	16-Φ29	AW20
500	600	1320	-	510	698	635	584	510	42.9	1.6	20-Φ32	AW25

※注：系列球阀结构长度及连接法兰尺寸可根据JB/T79标准或用户要求设计制造。  
 ※注：数据XXX/XXX分别是气动执行器双作用式/单作用式(弹簧复位)。  
 ※注：根据不同阀门扭矩、使用介质适配的执行器型号可能有所不同，相关尺寸随之变化。  
 ※注：以上执行器配置及数据均采用软密封(F、N、P)阀门，硬密封阀门的配置及数据请咨询本公司。  
 Note: The structural length and connecting flange size of ball valve series can be designed and manufactured as per JB/T79 standard or users' requirements  
 Note: Data XXX/XXX represent respectively the double-acting/single-acting type(spring reposition)of pneumatic actuator  
 Note: The relative sizes are subject to change responding to the difference in valve torque, medium and actuator model  
 Note: the above actuator configuration and data all use soft-sealed valves (F, N, P) and hard-sealed valves, or consulting us if you have more questions.