

产品参数 Technical Parameters

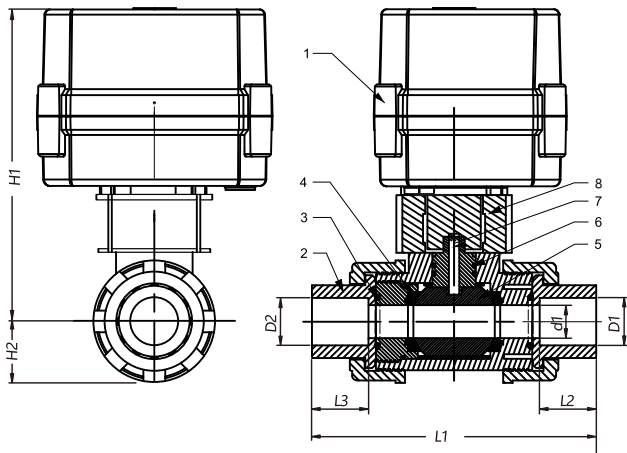

产品规格	Product Specifications	DN15~DN50
最大工作压力	Max. Working Pressure	1.0MPa
流通介质	Circulation Medium	Water, Air
额定电压	Rated Voltage	AC/DC 110-230V, DC9-24V (Optional)
开关的时间	Open/Close Time	≤12S
寿命	Life Time	70,000 Times
阀体材料	Valve Material	UPVC
执行器材料	Actuator Material	Engineering Plastics
执行器扭矩	Torque Output	15.0N.M
环境温度	Ambient Temperature	-15°C-50°C
液体温度	Liquid Temperature	2°C-90°C
线长	Cable length	0.5m, 1.5m (Optional)
手动方式	Manual Override	YES
阀开关指示窗	Indicator	YES
旋转角度	Actuator rotation	90°
密封件	Sealing Material	FKM & PTFE
防护等级	Protection Class	IP67



主要零件材质表 Main Parts Materials

NO.	名称 Name	材质 material
1	执行器 Actuator	PPO A150
2	阀体 Body Cover	UPVC
3	O型圈 O-Ring	EPDM
4	密封件 Sealing	PTFE
5	球体 Ball	UPVC
6	阀杆 Stem	STAINLESS STEEL 304
7	O型圈 O-Ring	EPDM
8	支架 Holder	STAINLESS STEEL

外形尺寸图 Outline Size Dimension

Size	D1/D2	d1	L1	L2/L3	H1	H2	D1/D2			
							ANSI	DIN	JIS	CNS
DN15	1/2"	5	104.8	22.3	136.7	27.5	21.54	20.3	22.4	22.4
DN20	3/4"	20	113	25.5	141.2	32	26.87	25.3	26.45	26.4
DN25	1"	25	127.2	28.6	156.25	37.25	33.65	32.3	32.55	34.5
DN32	1-1/4"	32	142	32	162.4	42.75	42.42	40.3	38.6	42.5
DN40	1-1/2"	40	157	35	174	50	48.56	50.3	48.7	48.6
DN50	2"	50	171	38	194.4	60	60.63	63.3	60.8	60.6

产品参数 Technical Parameters

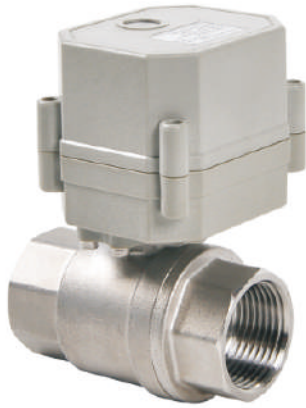

产品规格	Product Specifications	DN08~DN50
最大工作压力	Max. Working Pressure	1.0MPa
流通介质	Circulation Medium	Water, Air
额定电压	Rated Voltage	AC/DC 110-230V, DC9-24V (Optional)
开关的时间	Open/Close Time	≤7S, ≤10S, ≤12S
寿命	Life Time	70,000 Times
阀体材料	Valve Material	SS304, SS316 (Optional)
执行器材料	Actuator Material	Engineering Plastics
执行器扭矩	Torque Output	2.0N.M, 10.0N.M, 15N.M
环境温度	Ambient Temperature	-15°C-50°C
液体温度	Liquid Temperature	2°C-90°C
线长	Cable length	0.5m, 1.5m (Optional)
手动方式	Manual Override	YES or NO (Optional)
阀开关指示窗	Indicator	YES or NO (Optional)
旋转角度	Actuator rotation	90°
密封件	Sealing Material	FKM & PTFE
防护等级	Protection Class	IP67

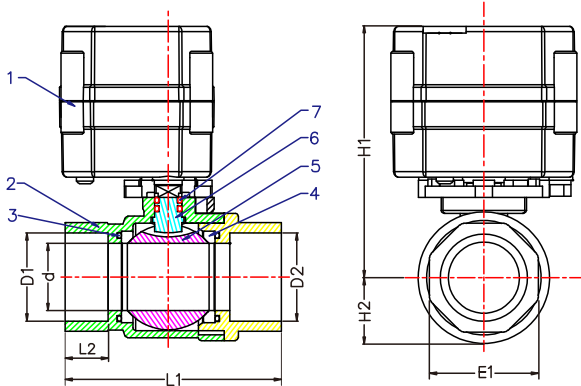

主要零件材质表 Main Parts Materials

NO.	名称 Name	材质 material
1	执行器 Actuator	PPO AT20/AT100
2	阀体 Body Cover	STAINLESS STEEL 304
3	O型圈 O-Ring	FKM
4	密封件 Sealing	PTFE
5	球体 Ball	STAINLESS STEEL 304
6	阀杆 Stem	STAINLESS STEEL 304
7	O型圈 O-Ring	FKM

外形尺寸图 Outline Size Dimension

Size	D1/D2	d	L1	L2	E1	H1	H2
DN08	1/4"	10	51	12	21	82	14
DN10	3/8"	10	51	12	21	82	14
DN15	1/2"	15	63	14	25	83	17
DN20	3/4"	20	72	17	31	87	20
DN25	1"	25	81	18	38	95	24
DN32	1-1/4"	32	102	23	47	122	31
DN40	1-1/2"	40	115	25	52	130	36
DN50	2"	50	130	25	66	138	45

产品参数 Technical Parameters

产品规格	Product Specifications	DN08~DN25
最大工作压力	Max. Working Pressure	1.0MPa
流通介质	Circulation Medium	Water, Air
额定电压	Rated Voltage	AC/DC 110-230V, DC9-24V (Optional)
开关的时间	Open/Close Time	≤15S
寿命	Life Time	70,000 Times
阀体材料	Valve Material	SS304, SS316 (Optional)
执行器材料	Actuator Material	Engineering Plastics
执行器扭矩	Torque Output	10.0N.M
环境温度	Ambient Temperature	-15°C-50°C
液体温度	Liquid Temperature	2°C-90°C
线长	Cable length	0.5m, 1.5m (Optional)
手动方式	Manual Override	NO
阀开关指示窗	Indicator	YES or NO (Optional)
旋转角度	Actuator rotation	90°
密封件	Sealing Material	FKM& PTFE
防护等级	Protection Class	IP67

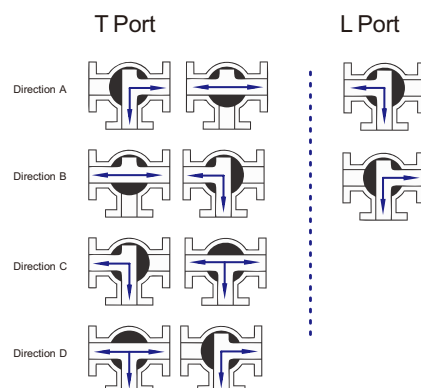

主要零件材质表 Main Parts Materials

NO.	名称 Name	材质 material
1	执行器 Actuator	PPO A100
2	阀体 Body Cover	STAINLESS STEEL
3	O型圈 O-Ring	FKM
4	密封件 Sealing	PTFE
5	球体 Ball	STAINLESS STEEL
6	阀杆 Stem	STAINLESS STEEL
7	O型圈 O-Ring	FKM

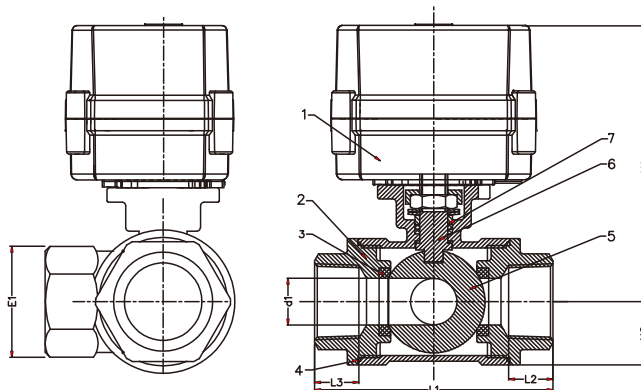

外形尺寸图 Outline Size Dimension

Size	D1/D2	d	L1	L2/L3	E1	H1	H2
DN08	1/4"	6	51	11	20.2	66	11
DN10	3/8"	6	51	11	20.2	66	11
DN15	1/2"	12	70	16	27	72	17
DN20	3/4"	15	75	16	31	76.5	20.5
DN25	1"	18	85	17	38	78	20.5

产品参数 Technical Parameters

产品规格	Product Specifications	DN15, DN20, DN25 (Optional)
最大工作压力	Max. Working Pressure	1.0MPa
流通介质	Circulation Medium	Water, Air
额定电压	Rated Voltage	AC/DC 110-230V, DC9-24V (Optional)
静态电流	Working Current	≤ 80mA
开关的时间	Open/Close Time	≤ 7S
寿命	Life Time	100,000 Times
阀体材料	Valve Material	SS304, SS316 (Optional)
执行器材料	Actuator Material	Engineering Plastics
时间设置范围	Keeping Valve Open Time	0H:0M:0S-99H:59M:59S
环境温度	Ambient Temperature	-15°C-50°C
液体温度	Liquid Temperature	2°C-90°C
手动方式	Manual Override	NO
阀开关指示窗	Indicator	YES
垫座	Gasket	PTFE
密封件	Sealing Material	FKM
防护等级	Protection Class	IP67

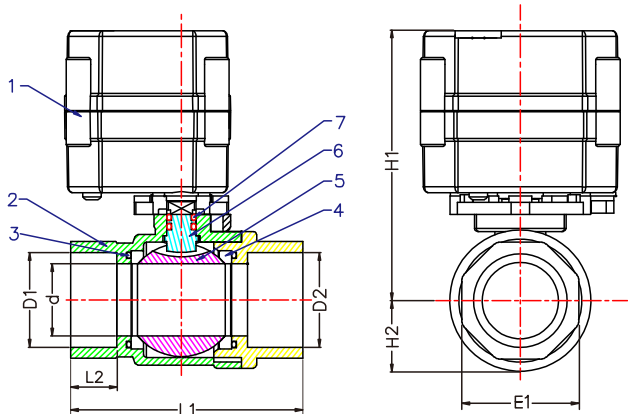

主要零件材质表 Main Parts Materials

NO.	名称 Name	材质 material
1	执行器 Actuator	PPO AT20/AT100
2	阀体 Body Cover	BRASS
3	O型圈 O-Ring	FKM
4	密封件 Sealing	PTFE
5	球体 Ball	BRASS
6	阀杆 Stem	STAINLESS STEEL 304
7	O型圈 O-Ring	FKM

外形尺寸图 Outline Size Dimension

Size	D1/D2	d	L1	L2	E1	H1	H2
DN08	1/4"	8	49	12	20.5	80.5	12
DN10	3/8"	10	49	12	20.5	80.5	12
DN15	1/2"	15	56	13	25	84	16
DN20	3/4"	20	66	15	31	87	19
DN25	1"	25	71	15	38	89	22
DN32	1-1/4"	32	79	20	46	91	25

产品参数 Technical Parameters

产品规格	Product Specifications	DN08~DN32
最大工作压力	Max. Working Pressure	1.0MPa
流通介质	Circulation Medium	Water, Air
额定电压	Rated Voltage	AC/DC 110-230V, DC9-24V (Optional)
开关的时间	Open/Close Time	≤7S, ≤10S, ≤12S
寿命	Life Time	70,000 Times
阀体材料	Valve Material	Brass, Nickel Plated Brass
执行器材料	Actuator Material	Engineering Plastics
执行器扭矩	Torque Output	2.0N.M, 10.0N.M, 15N.M
环境温度	Ambient Temperature	-15°C-50°C
液体温度	Liquid Temperature	2°C-90°C
线长	Cable length	0.5m, 1.5m (Optional)
手动方式	Manual Override	YES or NO (Optional)
阀开关指示窗	Indicator	YES or NO (Optional)
旋转角度	Actuator rotation	90°
密封件	Sealing Material	FKM & PTFE
防护等级	Protection Class	IP67



主要零件材质表 Main Parts Materials

NO.	名称 Name	材质 material
1	执行器 Actuator	PPO AT20/AT100
2	阀体 Body Cover	BRASS
3	O型圈 O-Ring	FKM
4	密封件 Sealing	PTFE
5	球体 Ball	BRASS
6	阀杆 Stem	STAINLESS STEEL 304
7	O型圈 O-Ring	FKM

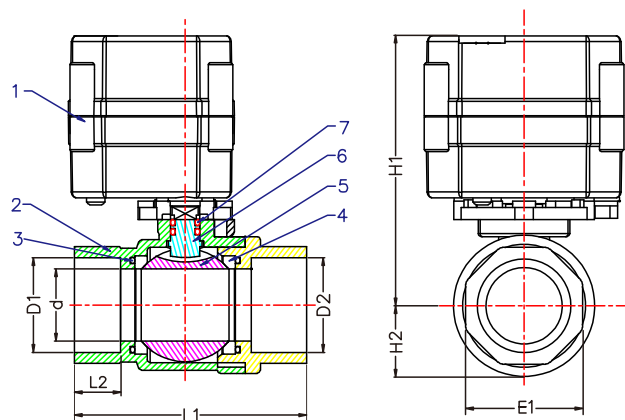

外形尺寸图 Outline Size Dimension

Size	D1/D2	d	L1	L2	E1	H1	H2
DN08	1/4"	8	49	12	20.5	80.5	12
DN10	3/8"	10	49	12	20.5	80.5	12
DN15	1/2"	15	56	13	25	84	16
DN20	3/4"	20	66	15	31	87	19
DN25	1"	25	71	15	38	89	22
DN32	1-1/4"	32	79	20	46	91	25

产品参数 Technical Parameters

产品规格	Product Specifications	DN08~DN25
最大工作压力	Max. Working Pressure	1.0MPa
流通介质	Circulation Medium	Water, Air
额定电压	Rated Voltage	AC/DC 110-230V, DC9-24V (Optional)
开关的时间	Open/Close Time	≤15S
寿命	Life Time	70,000 Times
阀体材料	Valve Material	SS304, SS316 (Optional)
执行器材料	Actuator Material	Engineering Plastics
执行器扭矩	Torque Output	10.0N.M
环境温度	Ambient Temperature	-15°C-50°C
液体温度	Liquid Temperature	2°C-90°C
线长	Cable length	0.5m, 1.5m (Optional)
手动方式	Manual Override	NO
阀开关指示窗	Indicator	YES or NO (Optional)
旋转角度	Actuator rotation	90°
密封件	Sealing Material	FKM & PTFE
防护等级	Protection Class	IP67

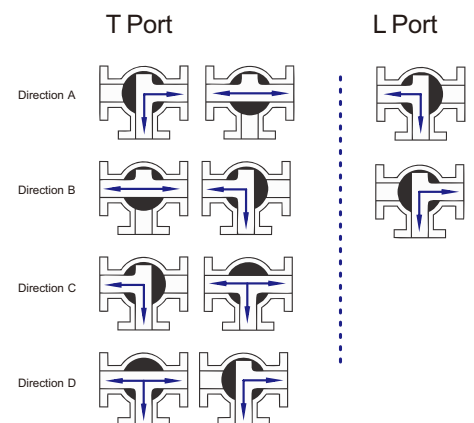

主要零件材质表 Main Parts Materials

NO.	名称 Name	材质 material
1	执行器 Actuator	PPO A100
2	阀体 Body Cover	STAINLESS STEEL
3	O型圈 O-Ring	FKM
4	密封件 Sealing	PTFE
5	球体 Ball	STAINLESS STEEL
6	阀杆 Stem	STAINLESS STEEL
7	O型圈 O-Ring	FKM

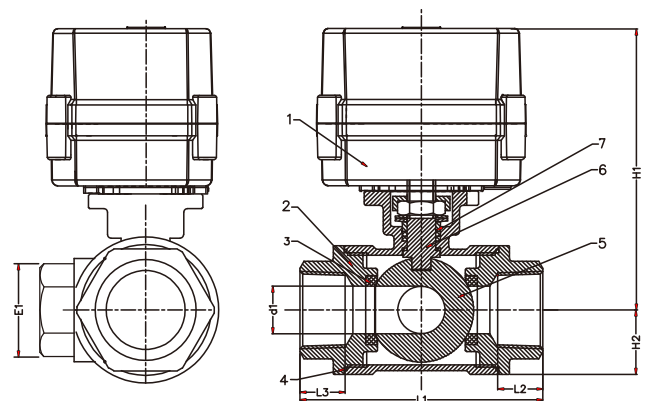

外形尺寸图 Outline Size Dimension

Size	D1/D2	d	L1	L2/L3	E1	H1	H2
DN08	1/4"	6	51	11	20.2	66	11
DN10	3/8"	6	51	11	20.2	66	11
DN15	1/2"	12	70	16	27	72	17
DN20	3/4"	15	75	16	31	76.5	20.5
DN25	1"	18	85	17	38	78	20.5



产品参数 Technical Parameters

产品规格	Product Specifications	DN15~DN25
最大工作压力	Max. Working Pressure	1.0MPa
流通介质	Circulation Medium	Water, Air
额定电压	Rated Voltage	AC/DC 110-230V, DC9-24V (Optional)
开关的时间	Open/Close Time	≤7S, ≤10S
寿命	Life Time	70,000 Times
阀体材料	Valve Material	Brass
执行器材料	Actuator Material	Engineering Plastics
执行器扭矩	Torque Output	2.0N.M, 10.0N.M
环境温度	Ambient Temperature	-15°C-50°C
液体温度	Liquid Temperature	2°C-90°C
线长	Cable length	0.5m, 1.5m (Optional)
手动方式	Manual Override	YES or NO (Optional)
阀开关指示窗	Indicator	YES or NO (Optional)
旋转角度	Actuator rotation	90°
密封件	Sealing Material	FKM & PTFE
防护等级	Protection Class	IP67

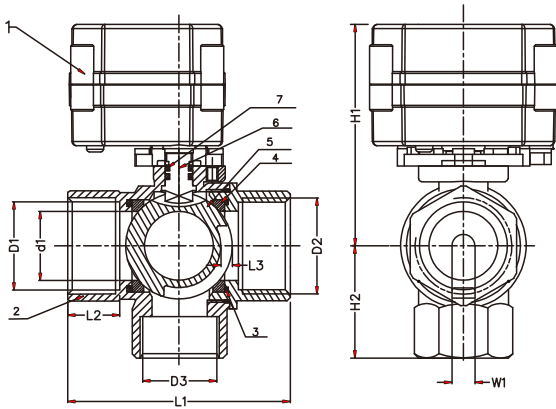
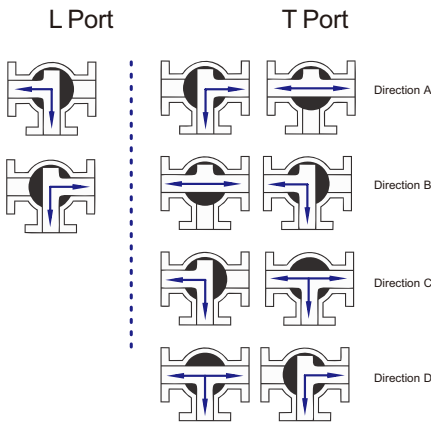

主要零件材质表 Main Parts Materials

NO.	名称 Name	材质 material
1	执行器 Actuator	PPO AT20/AT100
2	阀体 Body Cover	BRASS
3	O型圈 O-Ring	FKM
4	密封件 Sealing	PTFE
5	球体 Ball	BRASS
6	阀杆 Stem	STAINLESS STEEL 304
7	O型圈 O-Ring	FKM

外形尺寸图 Outline Size Dimension

Size	D1/D2	d1	W1	L1	L2	L3	H1	H2
DN15	1/2"	12	7	58	10	3	70	27
DN20	3/4"	15	7	66	16	3	71	31
DN25	1"	24	8	73	16	4	77	40

产品参数 Technical Parameters

产品规格	Product Specifications	DN15, DN20, DN25 (Optional)
最大工作压力	Max. Working Pressure	1.0MPa
流通介质	Circulation Medium	Water, Air
额定电压	Rated Voltage	AC/DC 110-230V, DC9-24V (Optional)
静态电流	Working Current	≤ 80mA
开关的时间	Open/Close Time	≤ 7S
寿命	Life Time	100,000 Times
阀体材料	Valve Material	Brass, Nickel Plated Brass
执行器材料	Actuator Material	Engineering Plastics
时间设置范围	Keeping Valve Open Time	0H:0M:0S-99H:59M:59S
环境温度	Ambient Temperature	-15°C-50°C
液体温度	Liquid Temperature	2°C-90°C
手动方式	Manual Override	NO
阀开关指示窗	Indicator	YES
垫座	Gasket	PTFE
密封件	Sealing Material	FKM
防护等级	Protection Class	IP67



主要零件材质表 Main Parts Materials

NO.	名称 Name	材质 material
1	执行器 Actuator	PPO AT20/AT100
2	阀体 Body Cover	BRASS
3	O型圈 O-Ring	FKM
4	密封件 Sealing	PTFE
5	球体 Ball	BRASS
6	阀杆 Stem	STAINLESS STEEL 304
7	O型圈 O-Ring	FKM

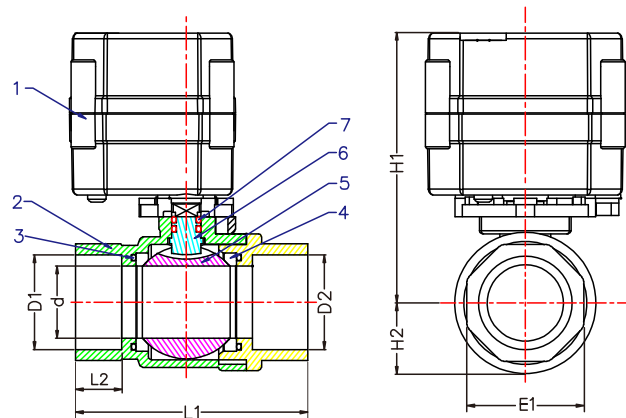

外形尺寸图 Outline Size Dimension

Size	D1/D2	d	L1	L2	E1	H1	H2
DN08	1/4"	8	49	12	20.5	80.5	12
DN10	3/8"	10	49	12	20.5	80.5	12
DN15	1/2"	15	56	13	25	84	16
DN20	3/4"	20	66	15	31	87	19
DN25	1"	25	71	15	38	89	22
DN32	1-1/4"	32	79	20	46	91	25

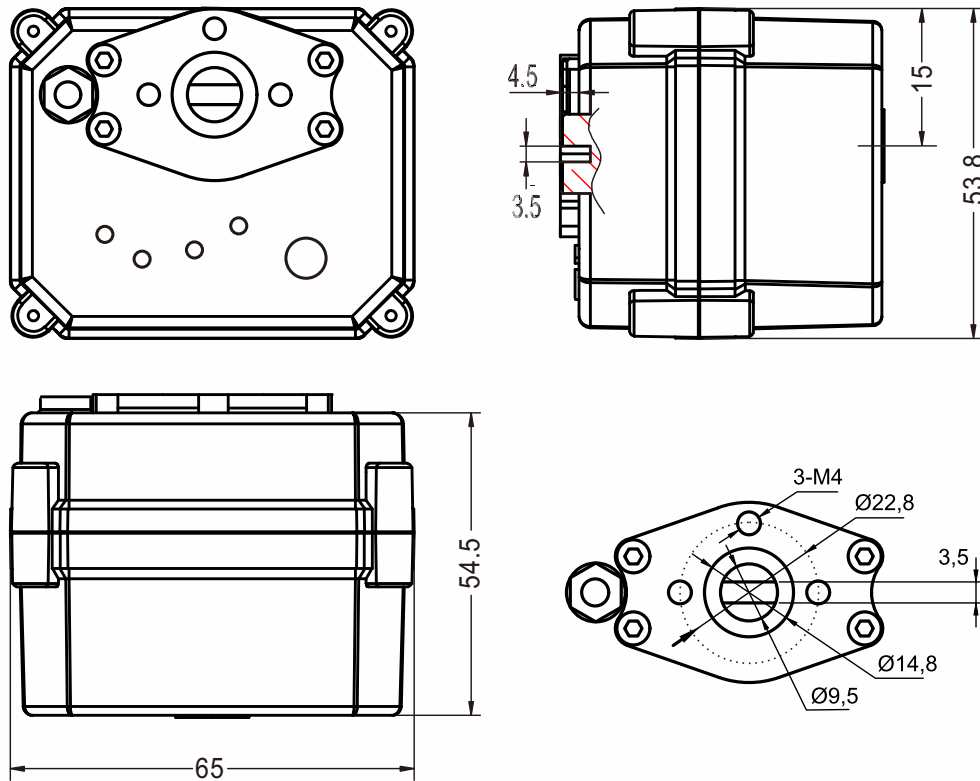

A20 Actuator Technical Parameters

Working Current	$\leq 500\text{mA}$
Max. Working Pressure	1.0MPa
Circulation Medium	Water, Air
Rated Voltage	AC/DC 110-230V, DC9-24V (Optional)
Open/Close Time	$\leq 5\text{S}$
Life Time	70,000 Times
Valve Material	SS304, SS316, BRASS, UPVC (Optional)
Actuator Material	Engineering Plastics
Torque Output	2.0N.M
Liquid Temperature	2°C-90°C
Ambient Temperature	-15°C-50°C
Cable length	0.5m, 1.5m (Optional)
Manual Override	YES or NO (Optional)
Indicator	YES or NO (Optional)
Actuator rotation	90°
Line Control	CR201, CR202, CR301, CR302, CR303, CR305, CR401, CR501, CR502, CR701, CR702, CR703, CR704, CR705, CR706 and External Regulation
Sealing Material	FKM & PTFE
Protection Class	IP67

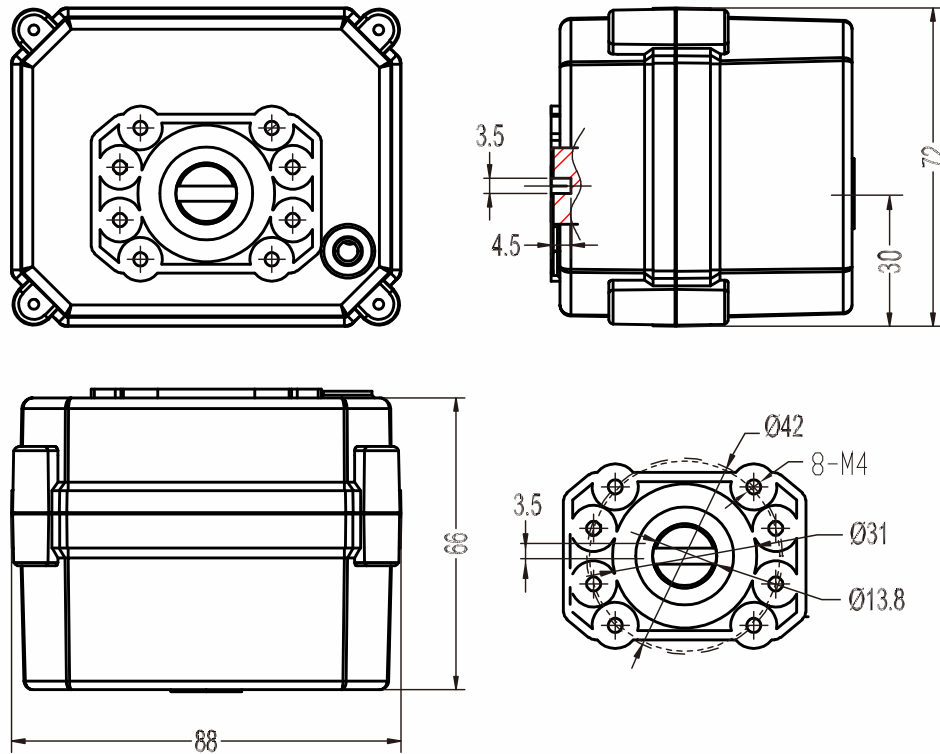

A100 Actuator Technical Parameters

Working Current	≤800mA
Max. Working Pressure	1.0MPa
Circulation Medium	Water, Air
Rated Voltage	AC/DC 110-230V, DC9-24V (Optional)
Open/Close Time	≤ 10S
Life Time	70,000 Times
Valve Material	SS304, SS316, BRASS, UPVC (Optional)
Actuator Material	Engineering Plastics
Torque Output	10.0N.M
Liquid Temperature	2°C-90°C
Ambient Temperature	-15°C-50°C
Cable length	0.5m, 1.5m (Optional)
Manual Override	NO
Indicator	YES or NO (Optional)
Actuator rotation	90°
Line Control	CR201, CR202, CR301, CR303, CR305, CR401, CR501, CR502, CR703, CR704, CR705, CR706 and External Regulation
Sealing Material	FKM & PTFE
Protection Class	IP67

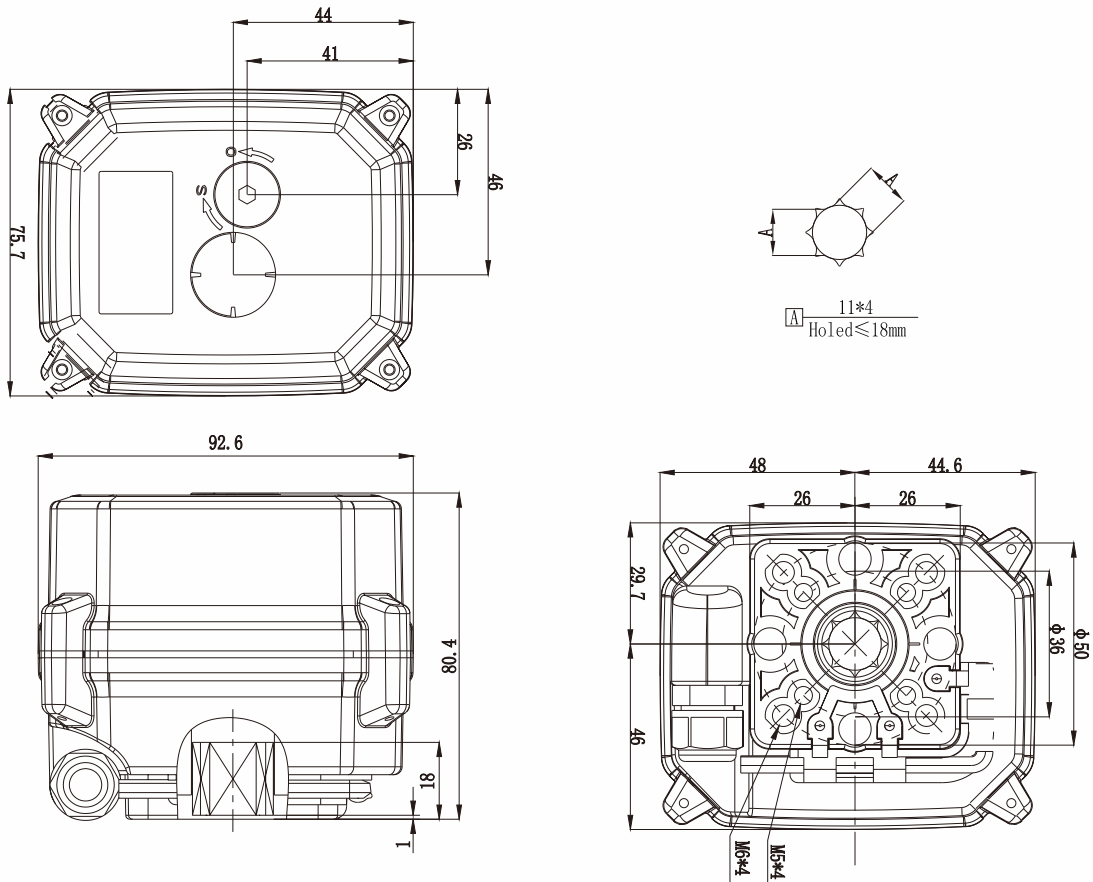

A150 Actuator Technical Parameters

Max. Working Pressure	1.0MPa
Circulation Medium	Water, Air
Rated Voltage	AC/DC 110-230V, DC9-24V (Optional)
Open/Close Time	$\leq 12\text{S}$
Life Time	70,000 Times
Valve Material	SS304, SS316, BRASS, UPVC (Optional)
Actuator Material	Engineering Plastics
Torque Output	15.0N.M
Liquid Temperature	2°C-90°C
Ambient Temperature	-15°C-50°C
Cable length	0.5m, 1.5m (Optional)
Manual Override	YES or NO (Optional)
Indicator	YES or NO (Optional)
Actuator rotation	90°
Line Control	CR201;CR202;CR301;CR303;CR306;CR501;CR502; CR702;CR703;CR706 and External Regulation
Sealing Material	FKM & PTFE
Protection Class	IP67



HK20-S-A Series

- Indicator
- Manual Override



HK20-S-B Series

- Indicator
- Manual Override



HK20-S-C Series

- Indicator
- Manual Override

CR2 01 Wiring Diagram (2 wires control)

- 1, RD connect with positive, the BK connect with negative, the valve closed, the actuator automatically power off after in place , the valve remains fully closed position
- 2, BK connect with positive, the RD connect with negative, the valve open, the actuator automatically power off after in place, the valve remains fully open position .

- * Suitable Working Voltage: DC5V/DC12V/DC24V
- * Exceeding the working voltage is forbidden

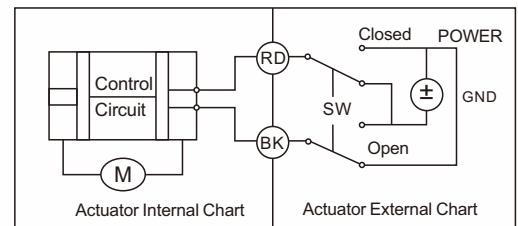

CR2 02 Wiring Diagram (2 wires control – Spring return in case of the power failure)

- 1, When SW is closed , the valve open. the actuator automatically power off after in place
- 2, When SW is open, the valve closed, the actuator automatically power off after in place

- * Suitable Working Voltage: AC/DC9-35V, AC/DC110V–230V
- * Exceeding the working voltage is forbidden

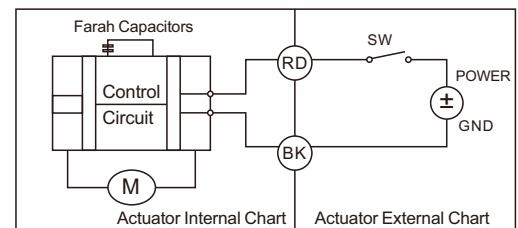

CR3 01 Wiring Diagram (3 wires control)

- 1, RD & GR connect with positive, BK connect with negative
- 2, When OPEN (RD) & SW connected, the valve open, the actuator automatically power off after in place, valve remains fully open position
- 3, When CLOSE (GR) & SW connected, the valve closed, the actuator automatically power off after in place, valve remains fully closed position

- * Suitable Working Voltage: DC5V,AC/DC9-24V
- * Exceeding the working voltage is forbidden

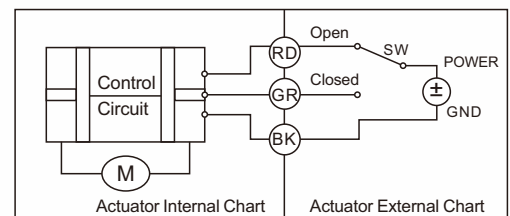

CR3 02 Wiring Diagram (3 wires control)

- 1, RD connect with positive, the BK & GR connect with negative
- 2, SW CLOSED, the valve OPEN, the actuator automatically power off after in place.
- 3, SW OPEN, the valve CLOSED, the actuator automatically power off after in place.

- * Suitable Working Voltage: DC9V-35V
- * Exceeding the working voltage is forbidden

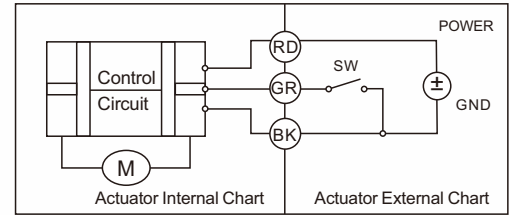

CR3 03 Wiring Diagram (3 wires control)

- 1, RD& GR connect with positive, the BK connect with negative
- 2, SW CLOSED, the valve OPEN, the actuator automatically power off after in place
- 3, SW OPEN, the valve CLOSED, the actuator automatically power off after in place.

- * Suitable Working Voltage: AC/DC9-24V,AC110-230V。
- * Exceeding the working voltage is forbidden

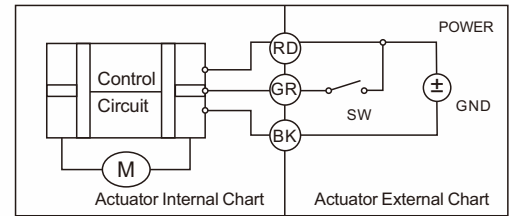

CR3 04 Wiring Diagram (3 wires control)

- 1, RD & GR connected with positive, and the BK connected with negative
- 2, When RD & SW connected, the valve closed, the actuator automatically power off after in place , remains fully closed position
- 3, When GR & SW connected, the valve open, the actuator automatically power off after in place, remains fully open position

- * Suitable Working Voltage: DC5V, DC12V, DC24V
- * Exceeding the working voltage is forbidden

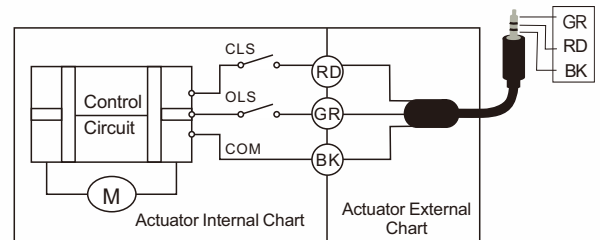

CR3 05 Wiring Diagram(3 wires control)

- 1, RD connect with positive, GR connect with SW & positive
- 2, BK connect with negative
- 3, When the SW of GR closed, the valve closed, the actuator automatically power off after in place , remains fully closed position
- 4, When the SW of GR open, the valve open, the actuator automatically power off after in place , remains fully open position

- * Suitable Working Voltage: AC/DC9-24V,AC110-230V。
- * Exceeding the working voltage is forbidden

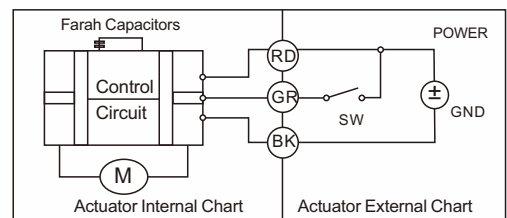

CR3 06 Wiring Diagram(3 wires control)

- 1, RD connect with positive, GR connect with SW & positive
- 2, BK connect with negative
- 3, When the SW of GR closed, the valve open, the actuator automatically power off after in place , remains fully closed position
- 4, When the SW of GR open, the valve closed, the actuator automatically power off after in place , remains fully open position.

- * Suitable Working Voltage: AC/DC9-24V,AC110-230V
- * Exceeding the working voltage is forbidden

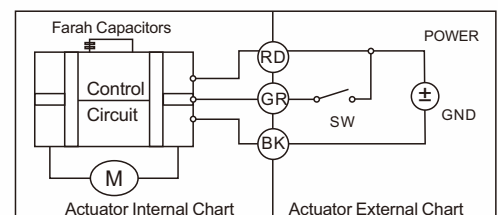

CR4 01 WIRING DIAGRAM(4 WIRES CONTROL)

- 1, RD&BK are connected to the power, WT&YW are connected to the controlled wiring.
- 2, When the sw is closed, the valve open
- 3, When the sw is open, the valve closed
- 4, Suitable working voltage: AC/DC110V-230V (No manual)
- 5, Exceeding the working voltage is forbidden

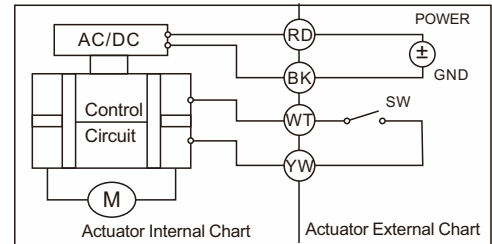

CR5 01 WIRING DIAGRAM (WITH FEEDBACK SIGNAL)

- 1, RD connect with positive, the BK connect with negative, the valve closed, the actuator automatically power off after in place
 - 2, BK connect with positive, the RD connect with negative, the valve open, the actuator automatically power off after in place
 - 3, BL & WT are connect when the valve open fully, YW&WT are connect when the valve closed fully
- * Suitable Working Voltage: DC5V/DC12V/DC24V
 - * Exceeding the working voltage is forbidden

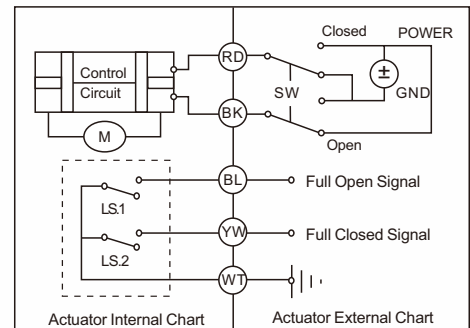

CR502 WIRING DIAGRAM (5 WIRES CONTROL – SPRING RETURN)

- 1, When SW is closed , the valve open. the actuator automatically power off after in place
 - 2, When SW is open, the valve closed, the actuator automatically power off after in place BL & WT are connect when the valve open fully, YW & WT are connect when the valve closed fully
- * Suitable Working Voltage: AC/DC9-24V, AC/DC110-230V,
 - * Exceeding the working voltage is forbidden

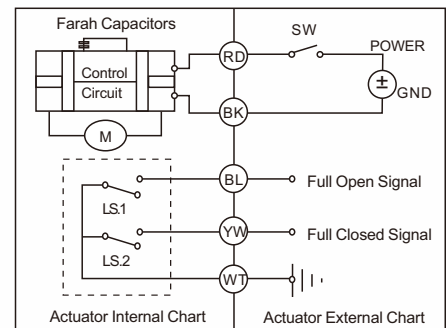

CR7 01 WIRING DIAGRAM (7 WIRES CONTROL)

- 1, RD connect with positive
 - 2, GR connect with SW and negative wiring
 - 3, BK connect with negative wiring
 - 5, SW closed. the valve closed, and keeping fully closed.
 - 6, BL & GY connect with the valve's fully open signal wiring
 - 7, YW & WT connect with the valve's fully closed signal wiring.
- * Suitable Working Voltage: DC9V-35V
 - * Exceeding the working voltage is forbidden
 - * Feedback with load ability

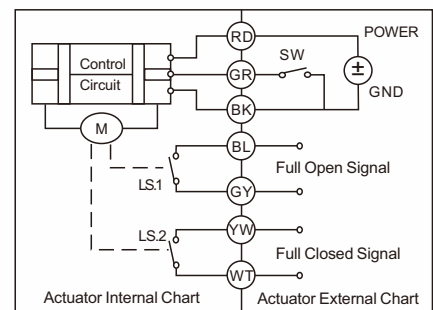

- ①The Max. off voltage: DC36V
- ②The Max. off current: 0.4A

CR7 02 Wiring Diagram (7 wires control)

1. RD & GR connect with positive, the BK connect with negative
2. When RD & SW connected, the valve open, the actuator automatically power off after the valve fully open.
3. When GR & SW connected, the valve closed, the actuator automatically power off after the valve fully closed.
4. BL & GY connect with the valve's fully open signal wiring
5. YW & WT connect with the valve's fully closed signal wiring

* Suitable Working Voltage: DC5V, DC12V, DC24V

* Exceeding the working voltage is forbidden

* Feedback with load ability

- ① The Max. off voltage: DC36V ② The Max. off current: 0.4A

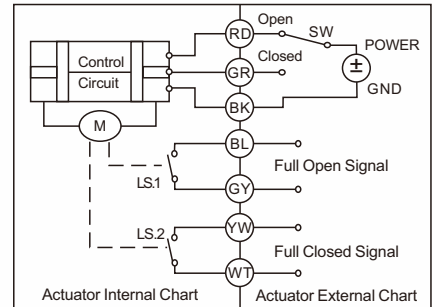

CR7 03 Wiring Diagram (7 wires control)

- 1, RD & GR connect with positive, the BK connect with negative
- 2, SW CLOSED, the valve OPEN, the actuator automatically power off after in place
- 3, SW OPEN, the valve CLOSED, the actuator automatically power off after in place
- 4, BL & GY connect with the valve's fully open signal wiring
- 5, YW & WT connect with the valve's fully closed signal wiring.

* Suitable Working Voltage: AC/DC9-24V, AC110-230V

* Exceeding the working voltage is forbidden

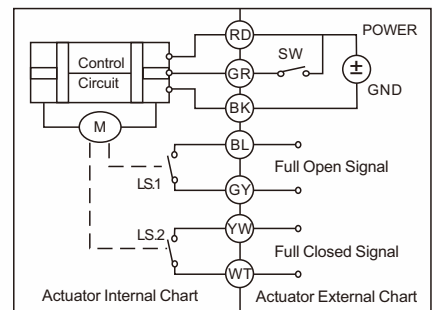

CR7 04 Wiring Diagram (7 wires control)

- 1, RD & BK are connected to the power, WT & YW are connected to the controlled wiring.
- 2, When the SW is closed, the valve open
- 3, When the SW is open, the valve closed
- 4, BL & GY connect with the valve's fully open signal wiring
- 5, YW & WT connect with the valve's fully closed signal wiring.

* Suitable Working Voltage: AC/DC110V-230V

* Exceeding the working voltage is forbidden

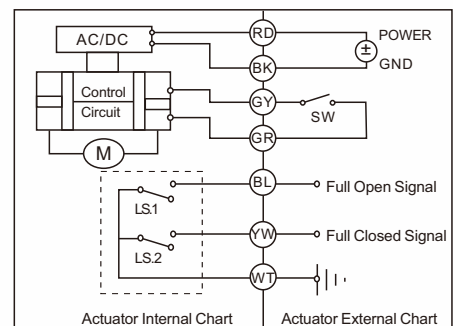

CR705 (7-wire control-with power-off reset and signal feedback function)

1. Power-off shut-off valve

1. Connect the red wire and the green wire to the positive pole, and the to the negative pole.
2. When the green line switch is closed, the valve opens. After the valve is opened, the blue line and the gray line are connected, and the valve stops automatically.
3. When the green line switch is off, the valve is closed. After the valve is closed, the yellow line and white line are connected, and the valve automatically stops.
4. The valve automatically closes after disconnecting the power

* Voltage selection: AC/DC9-24V AC110-230V

* Do not exceed the voltage to work

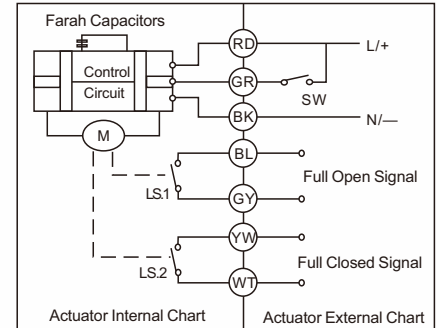

2. Turn off the power and open the valve

1. Connect the red wire and the green wire to the positive pole, and the black wire to the negative pole.
2. When the green line switch is closed, the valve is closed. After the valve is closed in place, the yellow line and white line are connected, and the valve stops automatically.
3. When the green line switch is off, the valve opens. After the valve is opened, the blue line and the gray line are connected, and the valve stops automatically.
4. The valve opens automatically after disconnecting the power

* Voltage selection: AC/DC9-24V AC110-230V

* Must not exceed voltage

CR706 (7-wire control --- with power-off reset and signal feedback function)

1. Power-off shut-off valve

1. Connect the red wire and the green wire to the positive pole, and the black wire to the negative pole.
2. When the green line switch is closed, the valve is closed. After the valve is closed, the yellow line and the white line are connected, and the valve stops automatically;
3. When the green line switch is off, the valve opens, and the blue line and gray line are connected after the valve is opened, and the valve stops automatically;
4. The valve automatically closes after disconnecting the external power supply

* Voltage selection: AC/DC9-24V AC110-230V

* Do not exceed the voltage to work

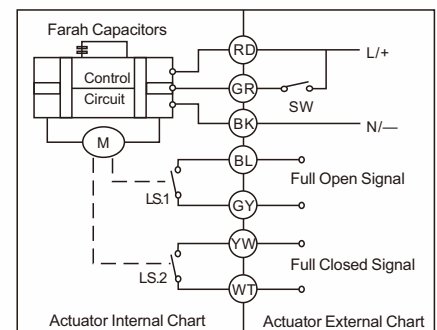

2. Turn off the power and open the valve

1. Connect the red wire and the green wire to the positive pole, and the black wire to the negative pole.
2. When the green line switch is closed, the actuator will turn counterclockwise and the valve will open. After the valve is opened, the blue line and gray line will be connected, and the valve will stop automatically;
3. When the green line switch is disconnected, the actuator will turn clockwise and the valve will be closed. After the valve is closed, the yellow and white lines will be connected, and the valve will stop automatically;
4. The valve opens automatically after disconnecting the external power supply

* Voltage selection: AC/DC9-24V AC110-230V

* Must not exceed voltage

Adjustable wiring diagram (5-wire control, supporting A20 actuator)

- 1, RD connects DC9–24V positive
 - 2, BK connects DC9 ~ 24V negative pole / 4–20mA negative pole
 3. YW is connected to the wrong output signal, OC output
 4. GR connected to P position input/control current positive/ control voltage positive (4–20mA)
 5. WT connects to position output, OC outputs PWM signal
- ☉ PWM frequency: 100Hz, duty: 5–95%

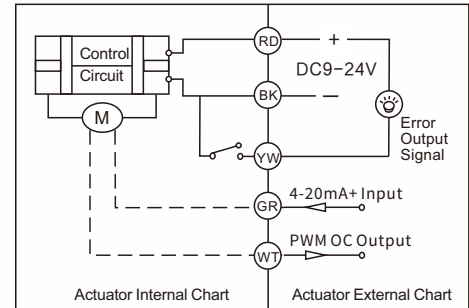

Adjustable wiring diagram (6-wire control, supporting A150 actuator)

- 1, RD connects DC9–24V positive
 - 2, BK connects DC9 ~ 24V negative pole / 4–20mA negative pole
 3. YW is connected to the wrong output signal, OC output
 4. GR connected to P position input/control current positive/ control voltage positive (4–20mA)
 5. WT connection position outputs 4–20mA signal
- ☉ PWM frequency: 100Hz, duty: 5–95%

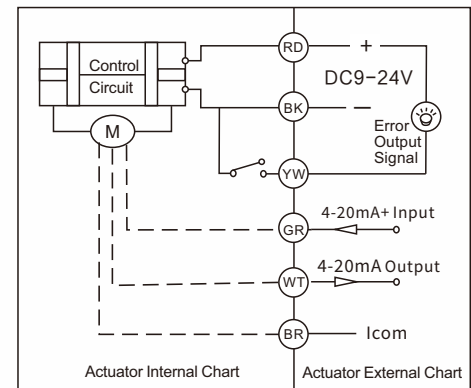

Manual override instructions:

In case of an electric supply failure, it is possible to operate the actuator manually:

- 1, Power must in off position when start the manual override.
- 2, Gently pull up the knob about 3mm, then revolve the knob around left and right to control the valve open or close.
- 3, When the red needle in the indicator pointing to S, means the valve is closed. When pointing to 0, means the valve is open.
- 4, After finish the manual override operation, must press down the knob, so that for the normal electric operation.



SOLENOID VALVE



ELECTRIC VALVE



PNEUMATIC VALVE



SPECIALIZED FLUID CONTROL VALVE MANUFACTURER

COVNA Headquarter:

Building C, Longchang Micro-Chuangyuan, No. 26 Hantang Street,
Dongcheng District, Dongguan City, China, 523000

E-mail: sales@covnavalve.com

Tel: 86-769-22456666 22763199

Fax: 86-769-22825120

www.covnavalve.com

www.covnaactuator.com